



TemplinTM
preserving life

BBR 100-D



TBBR-100-D

● Features

- Upright
- Capacity (L) 94 L.
- Range +4 °C

BLOOD BANK REFRIGERATOR WITH TRUE DUAL™ COOLING TECHNOLOGY

Optimal choice for safe and reliable storage of blood. These models are MDD certified and designed with stable and reliable temperature uniformity from top to bottom..

SAFE BLOOD STORAGE

The BBR range comes with many special features compared to a standard pharmaceutical refrigerator. To meet the strict requirements of the MDD approval, they come with probes immersed in glycerin, extra security controller, chart recorder and secondary probes, all to preserve the integrity and traceability of the precious blood. The BBR range comes as standard with telescopic drawer systems with lanes and dividers so that you can sort and extract the stored samples with minimum efforts – taking up less time when it really matters

OPTIMIZED INTERIOR

The valuable blood is well protected and monitored in our blood banks, ensuring the high quality of your blood bags at all times. Insulated double pane glass doors will prevent condensation and ensures great temperature uniformity. Together with the smart design, glass door and the telescopic drawers in Arctiko's BBR range you are ensured to have maximum capacity of blood bag, a great access and overview of the stored samples and still keeping the blood safe.

Telescopic drawer systems with lanes and dividers so you can sort and extract the stored samples with minimum efforts.



TRUE DUAL TECHNOLOGY

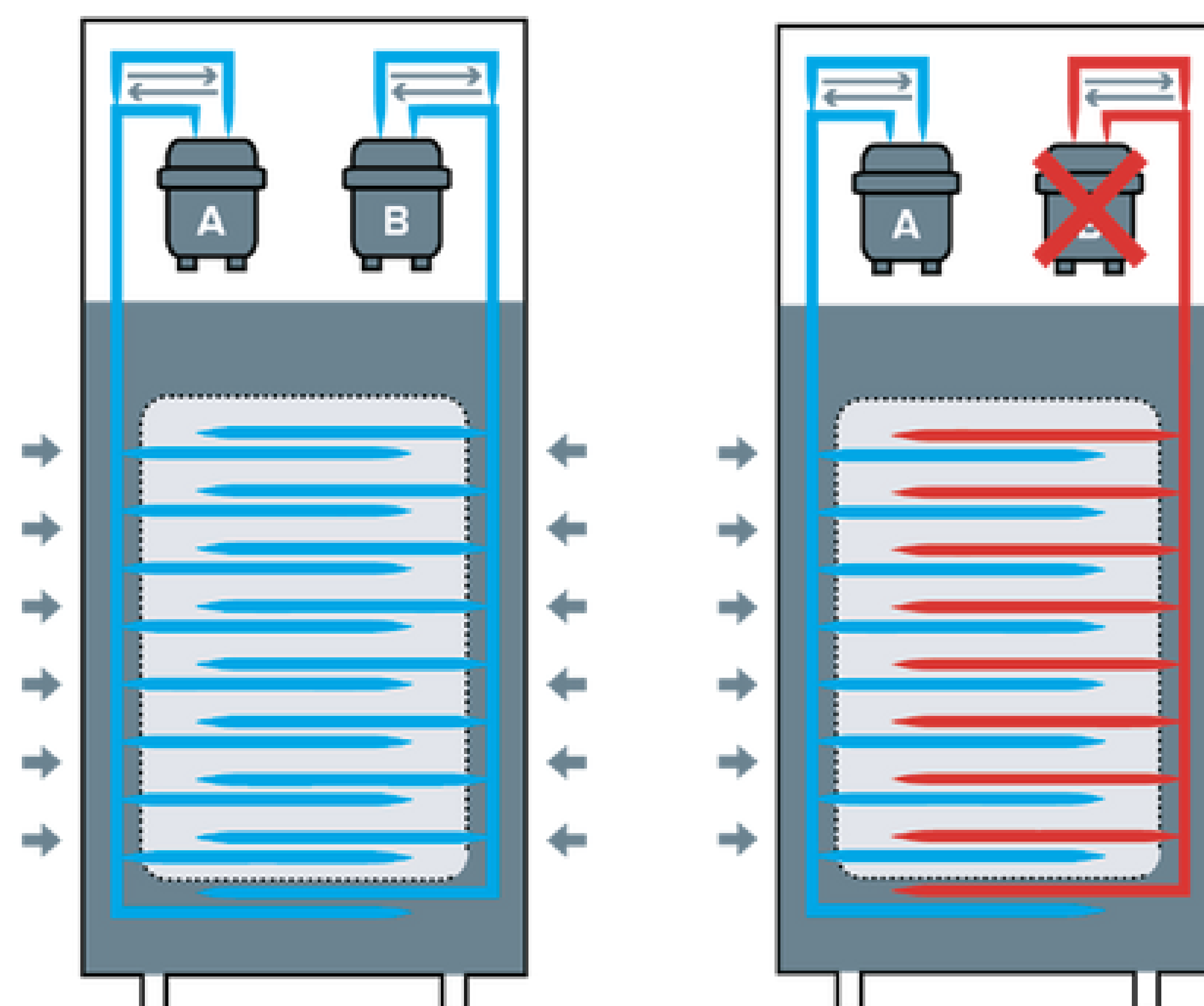

In case of a failure, the TRUE DUAL™ technology maintains a stable temperature of +4 °C and protects the blood.

MAIN DIMENSIONS

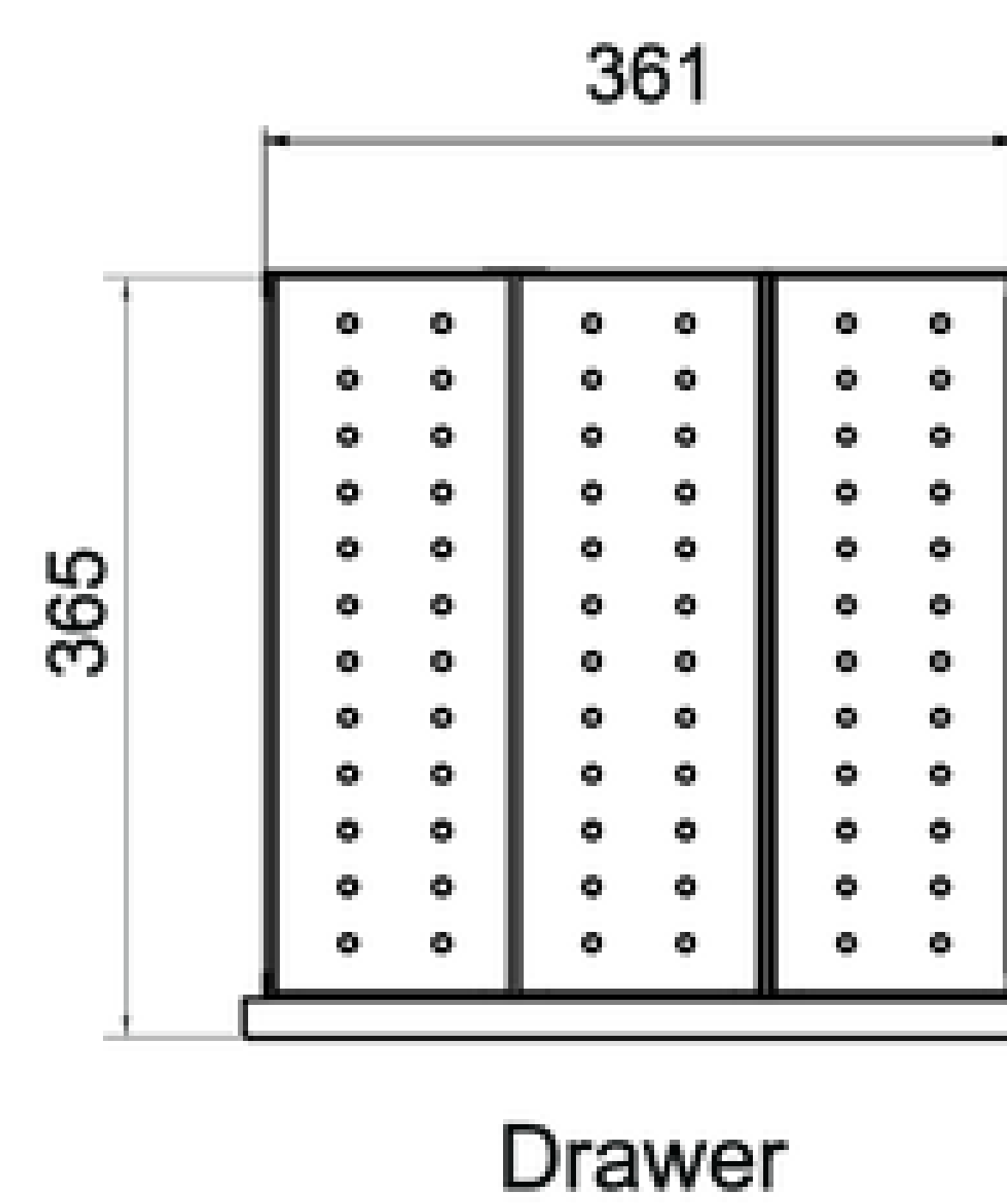
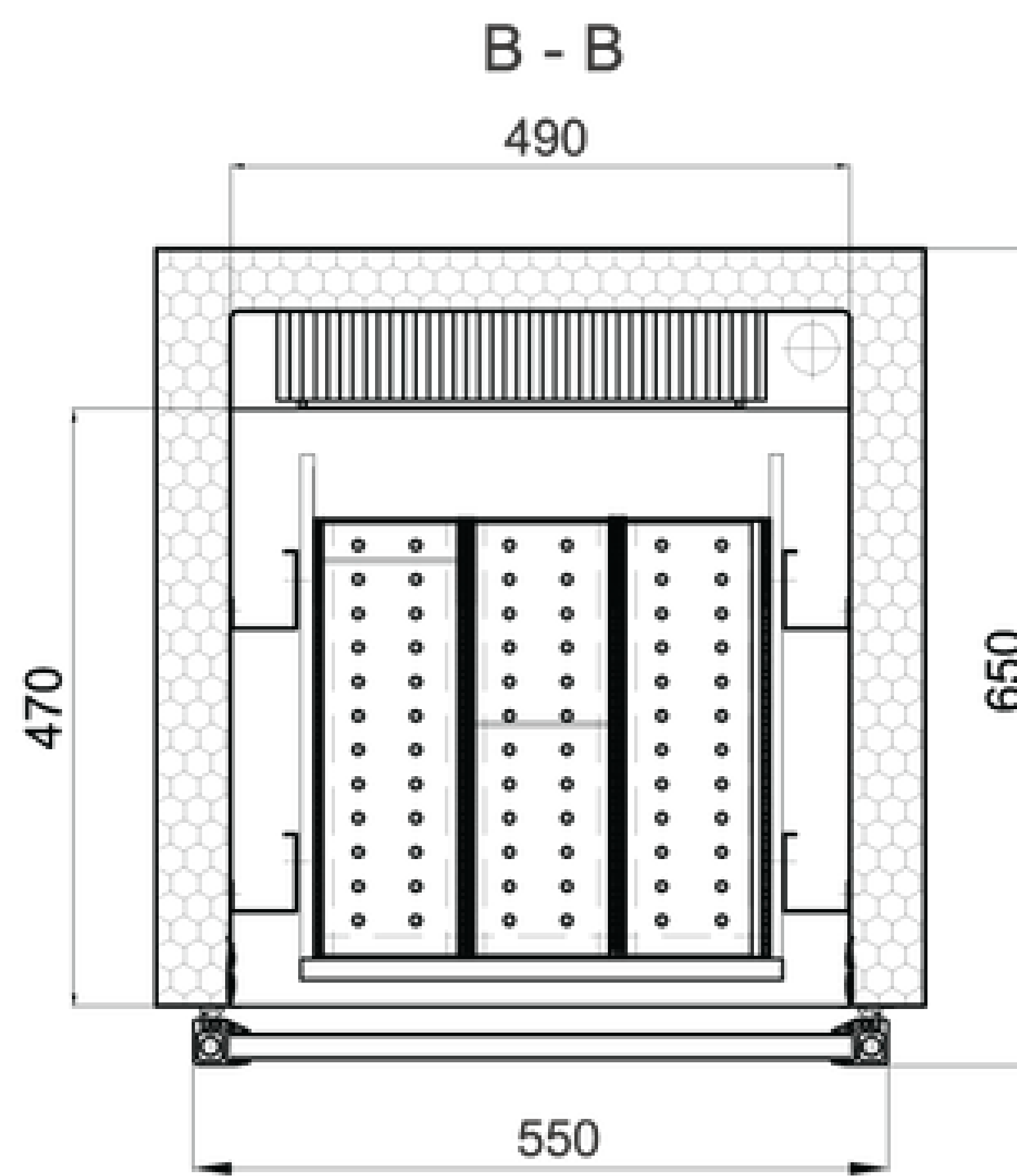
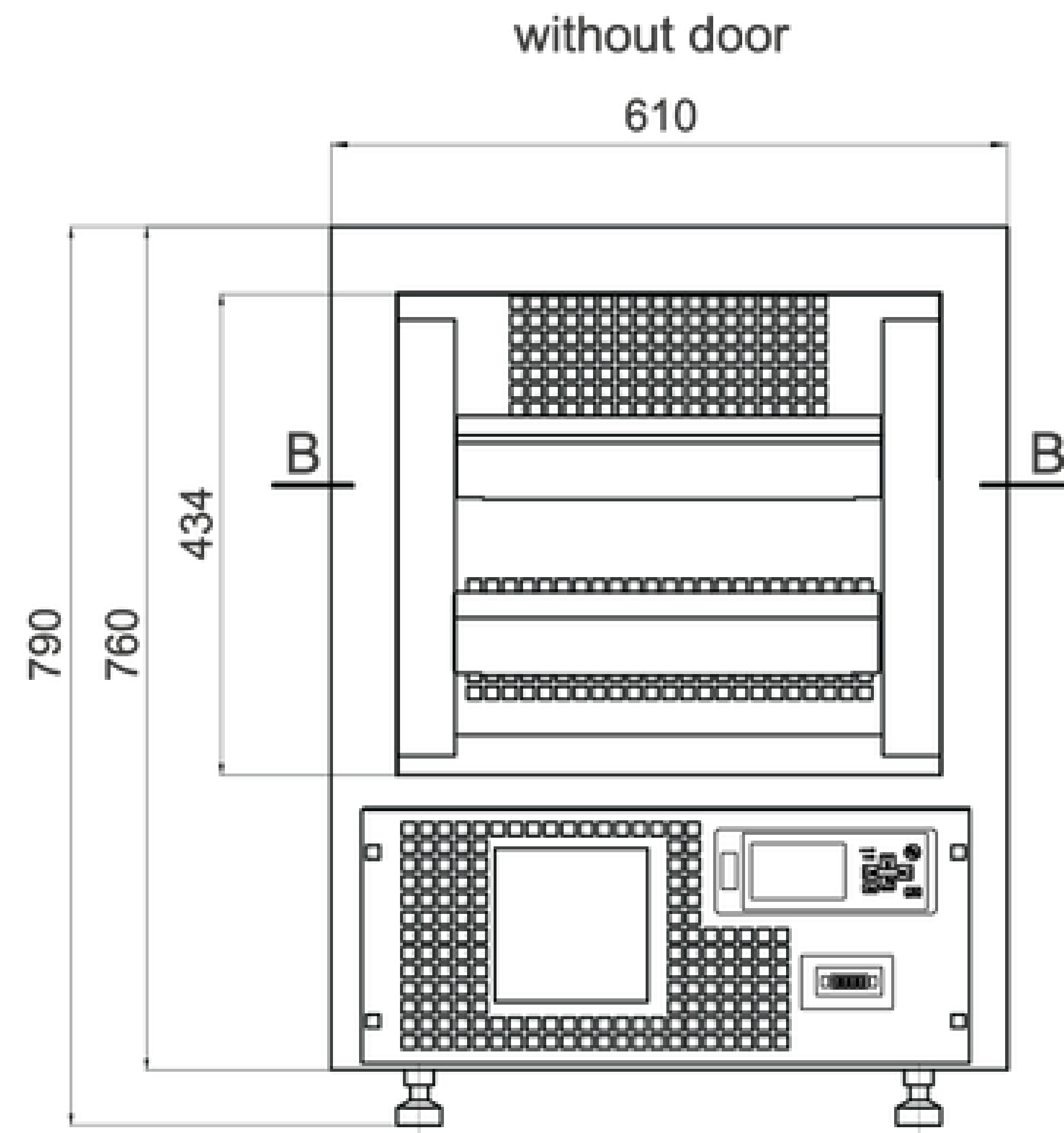

OPTIONAL FEATURES

- GSM alarm module
- Modbus adapter
- Voltage stabilizer
- Voltage converters

MODEL	TBBR-100-D	
Specifications	Item code	DAI 1135
	Temperature range (°C)	+4
	Max. ambient temperature (°C)	32
	Capacity (L)	94
	Exterior dimensions WxDxH (mm)	610x659x790
	Interior dimensions WxDxH (mm)	490x440x434
	Weight (KG)	86
	Insulation (mm)	60
	Cooling technology	forced air
	Controller Model / probe type	G214 / PT1000
Power	Power supply (V)	230
	Frequency (Hz)	50/60
	Power consumption (kWh/24h)	4.3
	AMP (A)	1.7
	Power (Watt)	264
	Horse power (HP)	2 x 1/10
Alarm Functions	Alarm display as text - not codes	yes
	Visual / acoustic alarm	yes / yes
	Power failure alarm	yes
	Adjustable high / low temperature alarm	yes / yes
	Open door alarm	yes
	Probe failure alarm	yes
	Low battery alarm	yes
	Compressor failure alarm	yes
	Battery backup for alarms (approx. hrs.)	72
Data logging & external connection	Voltage free contact for remote alarm (e.g. GSM alarm module)	yes
	Electronic data logger	yes
	RS 485 port	yes
	USB port for software update & data download	yes
	Temperature chart recorder	yes
Display Features	Display type	4,3" with touch buttons
	Number of optional reference probes	2
	Password protection for turning unit on / off	yes
	Temperature graph on display	yes
Features	Automatic defrost	yes
	Antifreeze function	no
	Vacuum release port	no
	Access port for external probe etc. (int. diameter mm)	optional
	Light	yes
	Lock with key	yes
	Castors (total pcs) / castors with brake (pcs)	2 rollers / 0
	Fixed feet (pcs) / levelling feet (pcs)	0 / 2
	Sub lids / inner doors (pcs)	no
	Reversible door(s)	no
	Fixed shelves (pcs) / adjustable shelves (pcs)	no
	Max. no. of shelves (pcs) / recommended max. no. of shelves (pcs)	no
	Max. load per shelf (kg)	no
	Adjustable drawers (pcs)	2
Max. load per adjustable drawer (kg)	30	
Max. no. of blood bags - by standard no. of adj. drawers (pcs)	72	
Refrigerator & Cabinet	Number of compressors	2
	Refrigerant	R290*
	Interior cabinet material	stainless steel
	Exterior cabinet material	painted steel
	Colour (exterior cabinet)	white
	Foam type	polyurethane
Shipping	VIP vacuum insulated panels	no
	Shipping weight (kg)	108
	Shipping dimensions WxDxH (cm)	81x69x103
	Shipping volume (m ³)	0,58



Email Us

info@tempinstruments.com

sales@tempinstruments.com

Address: 260 Salmon St, London NW9 8XY, United Kingdom